

# nuLabel™

Printing Solutions

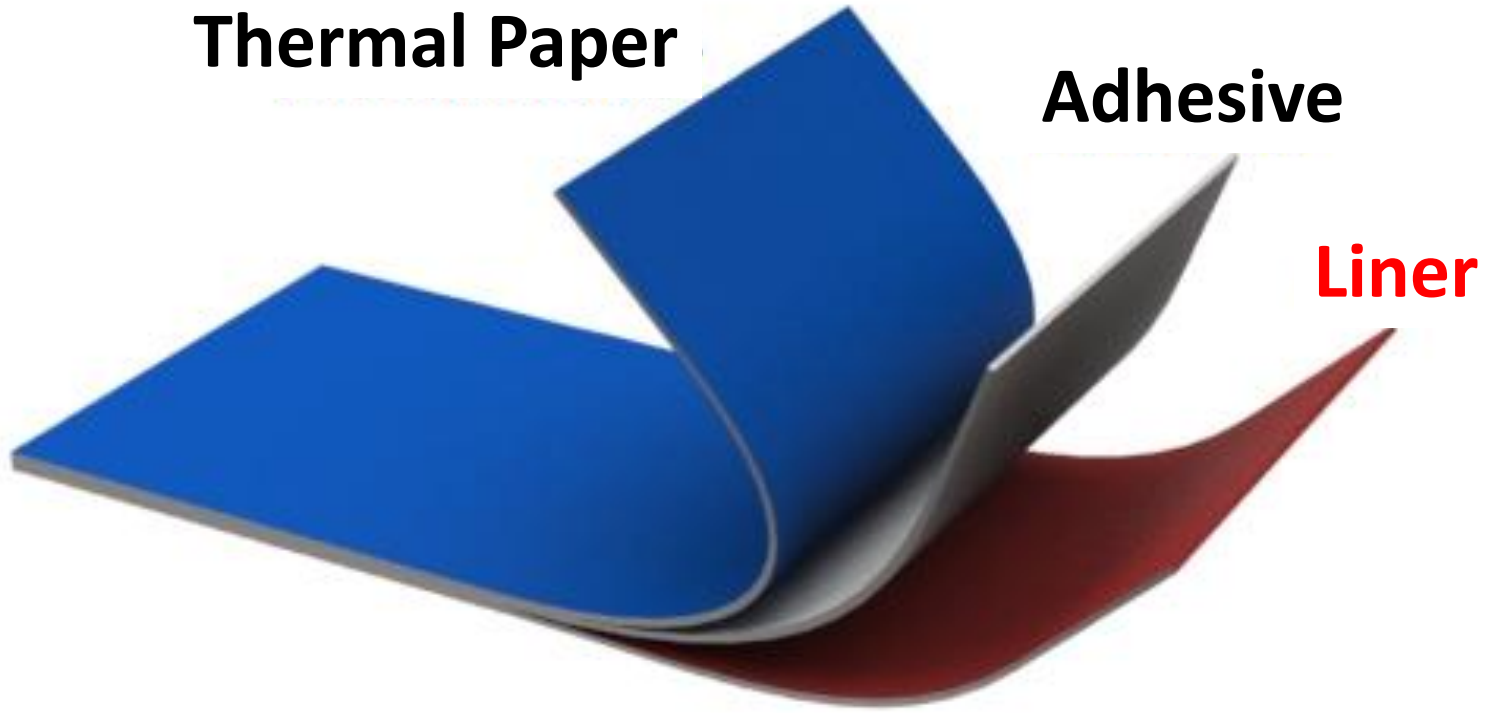

# Labels Have an Inherent Problem



# NuV Solution Eliminates Liners

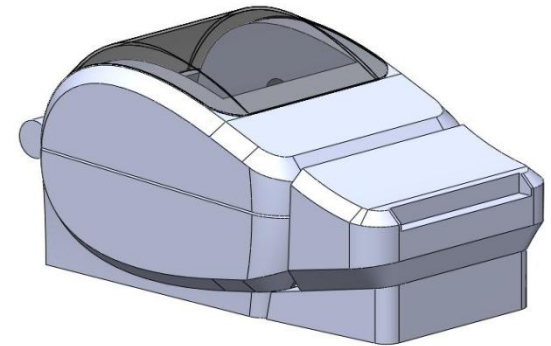
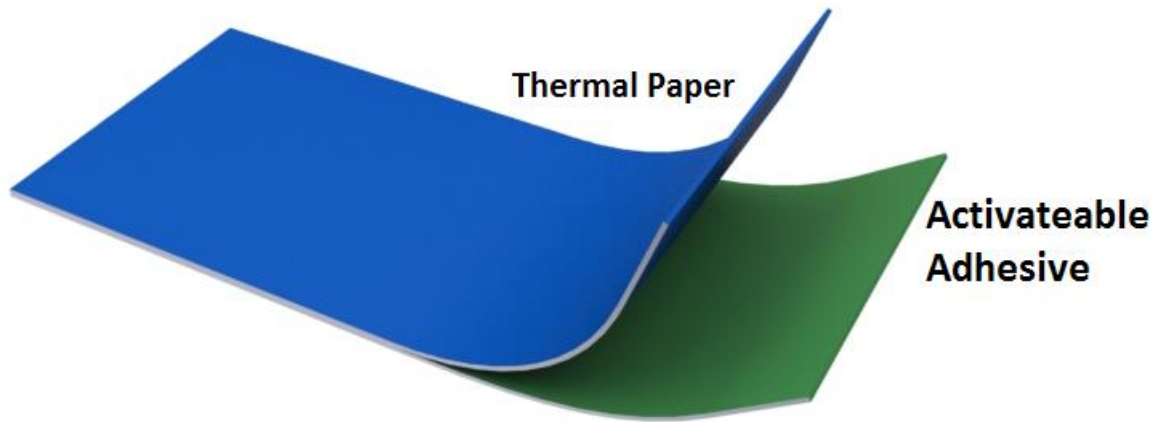
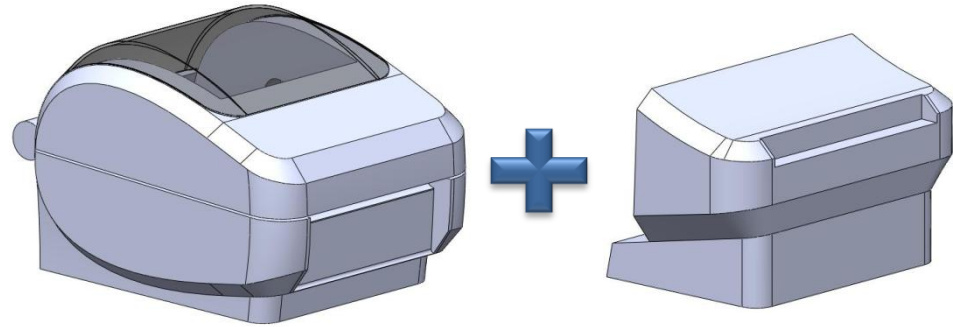
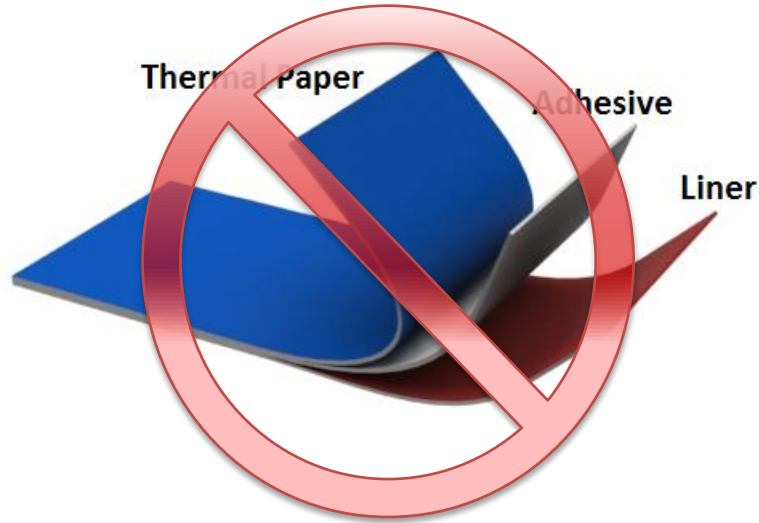

# Two Revenue Streams

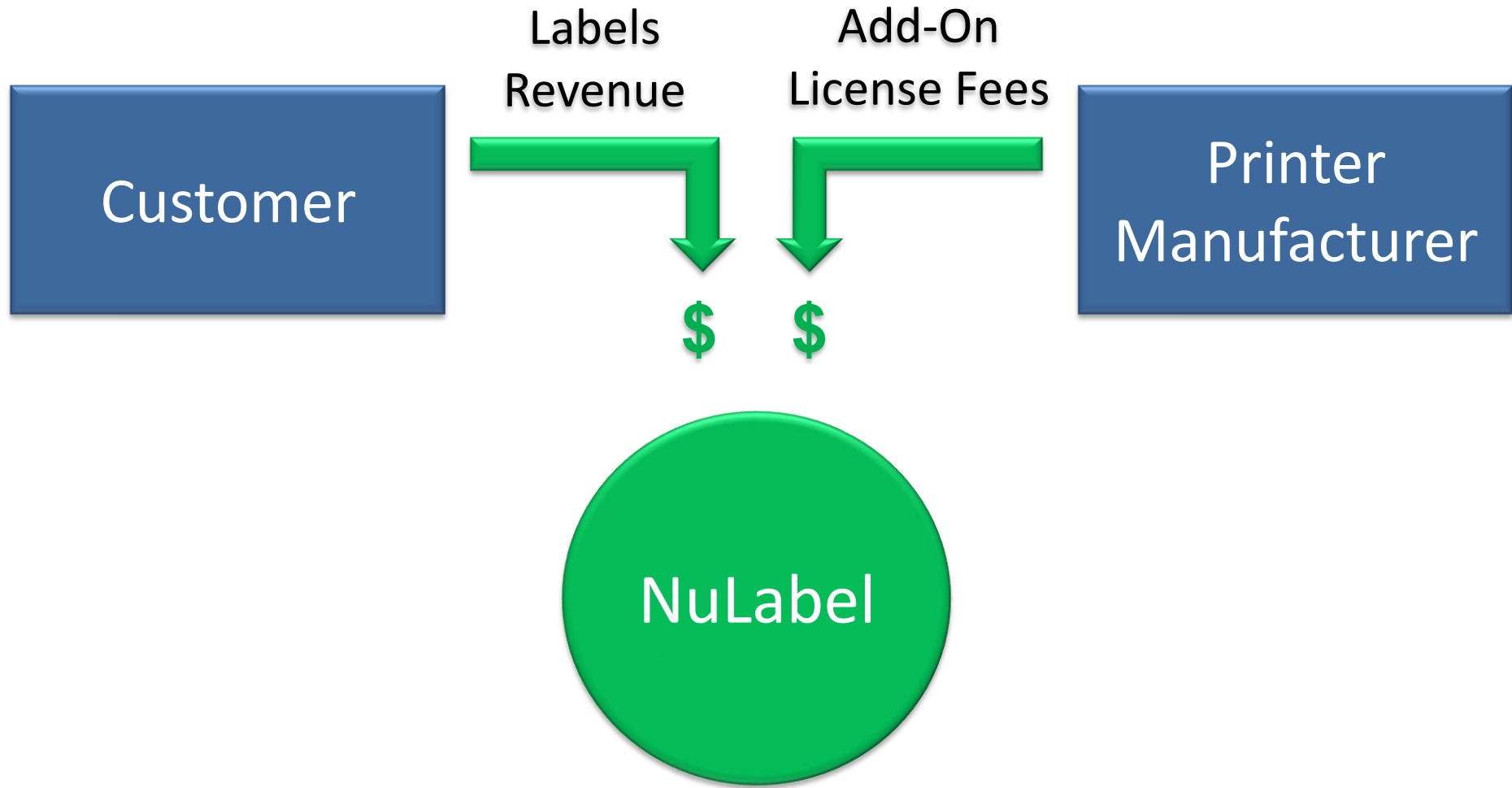

# Creating Value throughout the Channel

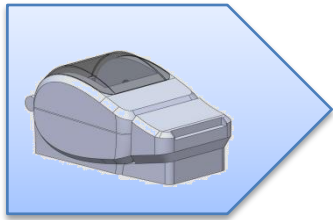

Printer OEM



Distributor



Re-Seller



End Users

NuLabel  
Printing Solutions

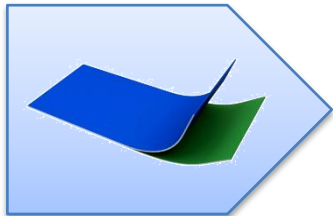

Coater



Converter



Re-Seller



Problem Solution Market Advantage Vision Opportunity

NuLabel  
Printing Solutions

# Disrupting the Status Quo



*Status Quo*

*In Development*



# Competitive Advantage

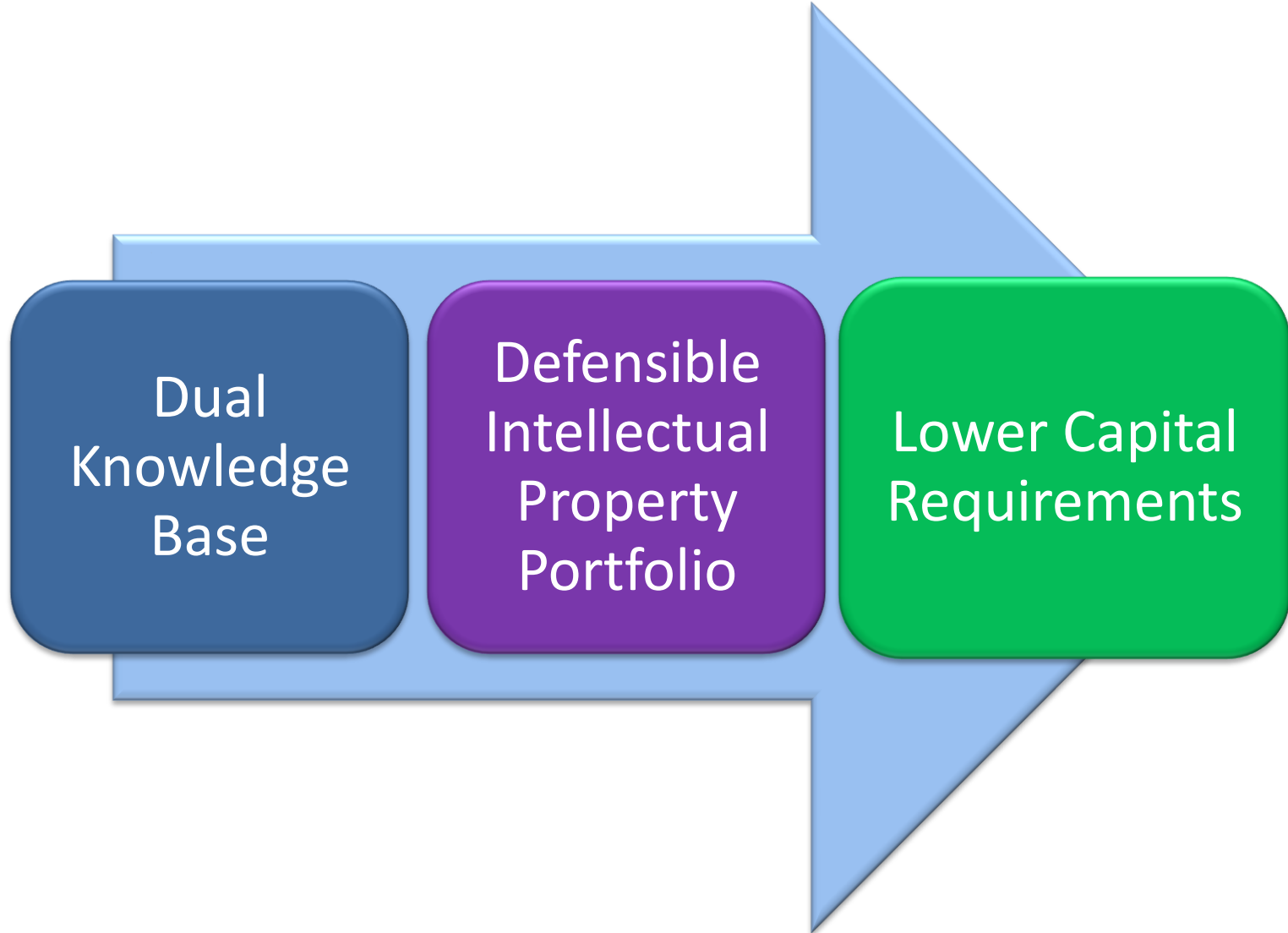

# Meet the Team

**Management**

Max Winograd,  
President

Alex Goracy,  
VP of Finance

Mike Woods,  
VP of Engineering

Ben Lux,  
VP of Technology

**Advisory Board**

Steven Petteruti,  
Former VP of Engineering at Comtec and Zebra

Dr. Edith Mathiowitz,  
Polymer Scientist and Serial Entrepreneur

Will Strobel,  
VP of Innovation at Zebra

Robert Danahy,  
Director of Technology at Zebra



# Proof of Concept to Beta Test

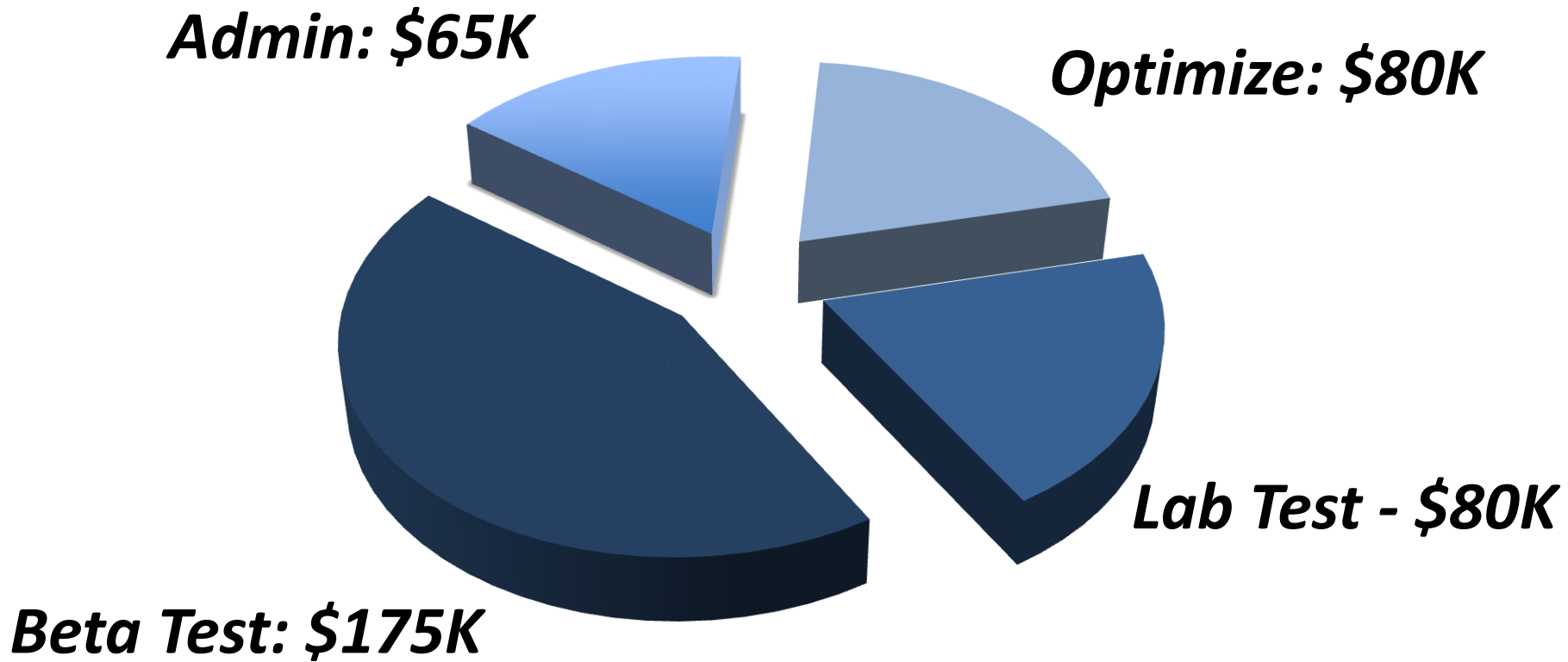

# Winning Over The Market

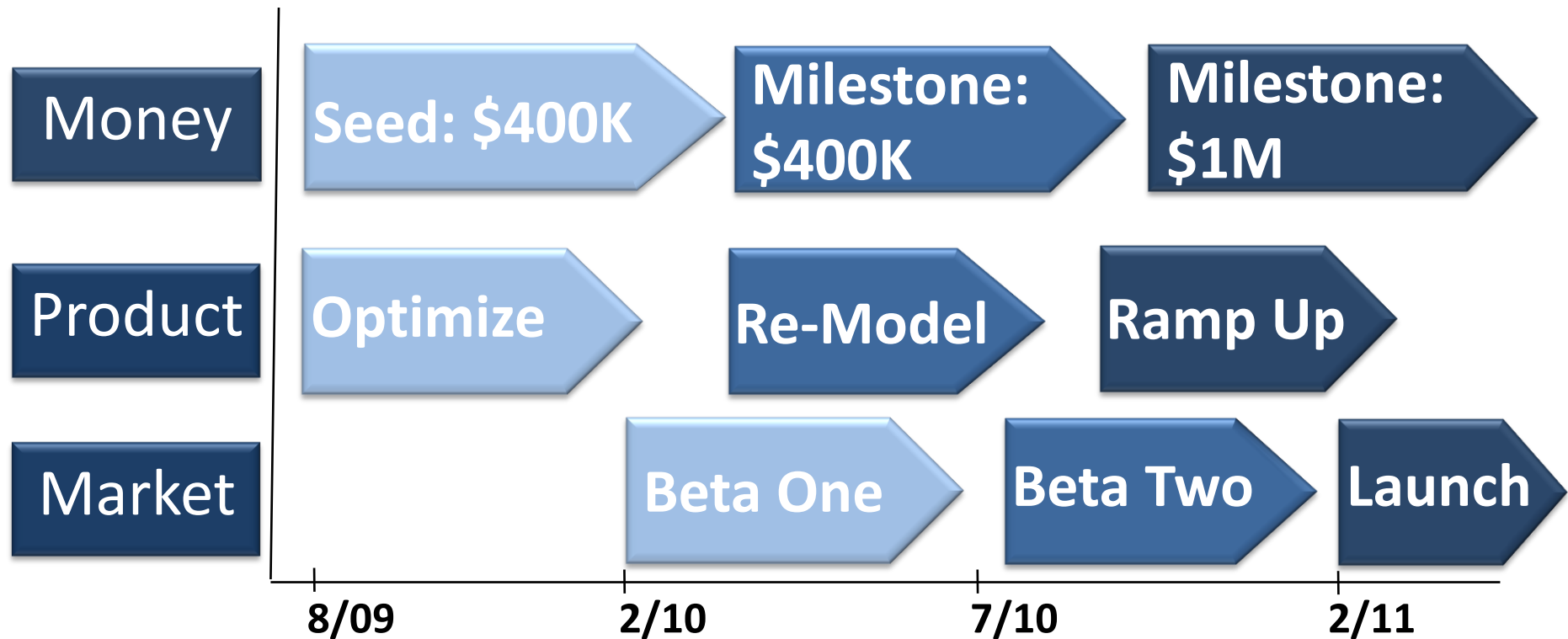

# Aggressive Growth Potential

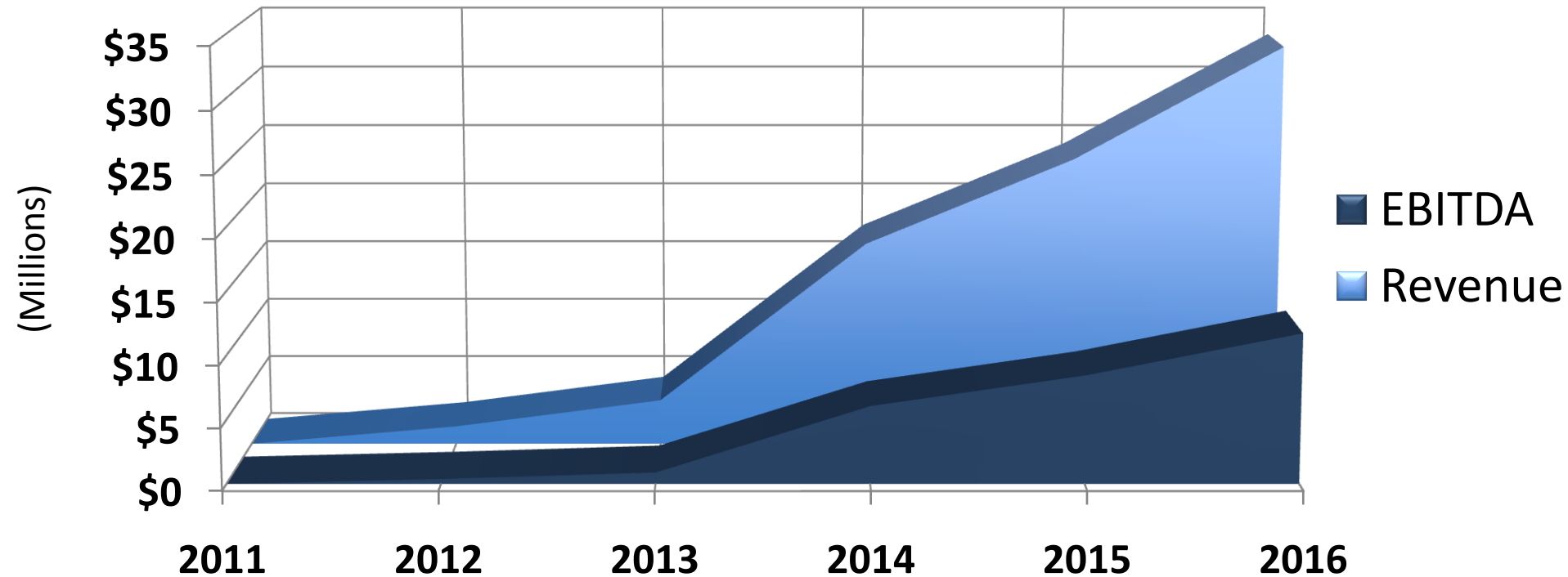

## Exit Pre-Revenue: \$18M

**Comparable:** BTG owned an RFID patent portfolio, had no products and was acquired by Zebra for \$10M.

## Exit 5 Years Post-Revenue: \$106M

**Comparable:** Comtec, leader of the mobile printer market, was acquired by Zebra for \$88M at \$10M in EBITDA.

# nuLabel™

---

Printing Solutions

**Print miles more for millions less.™**